

Option selector

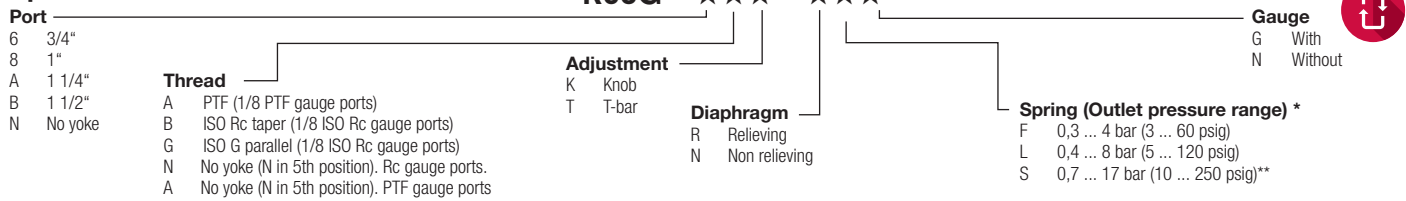

* Outlet pressure can be adjusted to pressures in excess of, and less than, those specified. Do not use these units to control pressures outside of the specified ranges.
** Available only with T-bar adjustment.

Technical features

Fluid: Compressed air
 Maximum pressure: 17 bar (250 psig)
 Operating temperature*:
 -20° ... +80°C (0° ... +175°F)
 * Air supply must be dry enough to avoid ice formation at temperatures below +2°C (+35°F).
 Typical flow with 10 bar (150 psig) inlet pressure, 6,3 bar (90 psig) set pressure and 1 bar (15 psig) droop from set: 170 dm³/s (370 scfm)
 Gauge ports:
 1/8" PTF with PTF main ports
 1/8" ISO Rc with ISO Rc main ports
 1/8" ISO Rc with ISO G main ports

Materials:
 Body: Aluminium
 Yoke: Aluminium
 Bonnet: Aluminium
 Adjusting knob: Acetal resin
 Valve: Aluminium
 Optional T-bar adjusting screw: Steel
 Elastomers: Synthetic rubber

Replacement Items
 Service kit, contains required items circled:
 Relieving 4381-300
 Non relieving 4381-301
 Tamper resistant cover and wire 4355-51

Installation

- Install yoke in air line -
 - with air flow in direction of arrow on top of yoke,
 - upstream of lubricators and cycling valves,
 - as close as possible to the device being served,
 - at any angle.
- Connect piping to yoke ports using pipe thread sealant on male threads only.
- Install a pressure gauge in regulator or plug gauge ports. Gauge ports can also be used as additional outlets for regulated air.
- Lubricate o-rings (15) with a light coat of o-ring grease, then place o-rings in grooves in body (14).
- Place clamp ring under lugs on top of yoke.
- Make sure arrows on yoke and regulator point in same direction, then plug regulator into yoke and tighten clamp ring hand tight.
- Install Norgren general purpose filter upstream of the regulator.

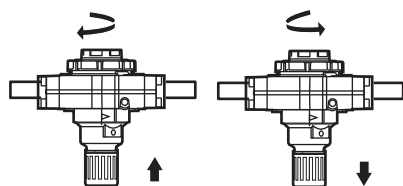

Adjustment

- Before applying inlet pressure to regulator, turn adjustment (1 or 7) counterclockwise to remove all force on regulating spring (11).
- Apply inlet pressure, then turn adjustment (1 or 7) clockwise to increase and counterclockwise to decrease pressure setting.
- Always approach the desired pressure from a lower pressure. When reducing from a higher to a lower setting, first reduce to some pressure less than that desired, then bring up to the desired pressure.

Note

With non-relieving regulators, make pressure reductions with some air flow in the system. If made under no flow (dead-end) conditions, the regulator will trap the over-pressure in the downstream line.

- Knob Adjustment. Push knob toward body to lock pressure setting. Pull knob away from body to release. Install tamper resistant cover and wire (see Replacement Items) to make setting tamper resistant.
- T-bar Adjustment. Tighten lock nut (8) lock pressure

Disassembly

- Shut off inlet pressure. Reduce pressure in inlet and outlet lines to zero.
- Turn adjustment (1 or 7) fully counterclockwise.
- Unscrew clamp ring and remove regulator from yoke.
- Disassemble in general accordance with the item numbers on exploded view.

Cleaning

- Clean parts with warm water and soap.
- Rinse and dry parts. Blow out internal passages in body with clean, dry compressed air.
- Inspect parts. Replace those found to be damaged.

Assembly

- Lubricate o-rings, valve stem (21), adjusting screw threads and tip (3, 7) and the recess of spring rest (10) with a light coat of good quality o-ring grease.
- Lubricate bonnet threads (2, 9) with a small amount of anti-seize compound.
- Assemble the unit as shown on the exploded view.
- Torque Table

Item	Torque in Nm	(Inch-Pounds)
2, 9 (Bonnet)	62 ... 68	(550 ... 600)
16 (Pipe plug)	3,3 ... 5,5	(29 ... 49)

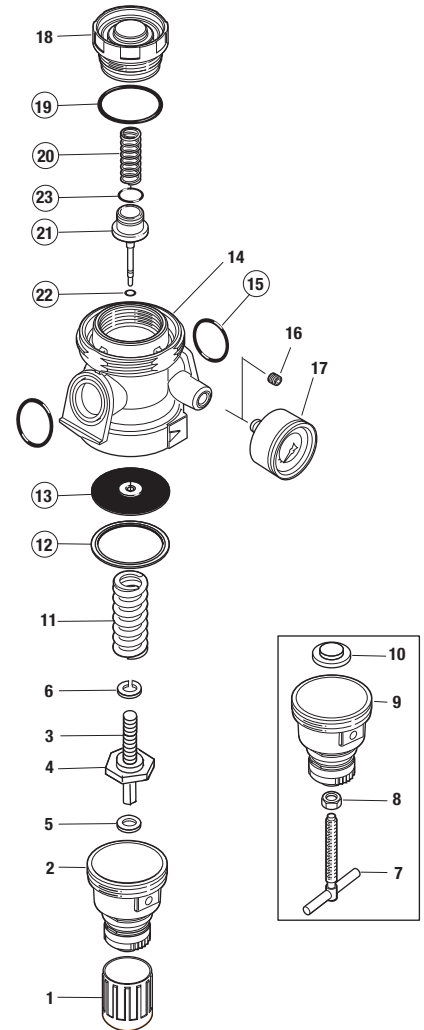

WARNING

These products are intended for use in industrial compressed air systems only. Do not use these products where pressures and temperatures can exceed those listed under Technical Data. If outlet pressure in excess of the regulator pressure setting could cause downstream equipment to rupture or malfunction, install a pressure relief device downstream of the regulator. The relief pressure and flow capacity of the relief device must satisfy system requirements.

The accuracy of the indication of pressure gauges can change, both during shipment (despite care in packaging) and during the service life. If a pressure gauge is to be used with these products and if inaccurate indications may be hazardous to personnel or property, the gauge should be calibrated before initial

installation and at regular intervals during use.
Before using these products with fluids other than air, for non industrial applications, or for life-support systems consult Norgren.

Use in potentially explosive atmospheres

Code of device according EC
directive 94/9/EC ExII 2 GD c TX

- Only non-flammable gases to be used as a medium.
- Surface temperature dependant on process fluid temperature and ambient temperature - must be below the ignition temperature of the flammable gas or dust.
- Earth unit and/or pipework to avoid electrostatic discharge.
- Precautions should be taken to prevent hazard from adiabatic compression.
- Use wet cloth for cleaning.
- Protect the unit from object falling onto it.
- Avoid contact with corrosive environment.
- For servicing the unit it is recommended to carry out this work outside of the danger zone.
- For details of ignition hazard assessment contact Norgren.